

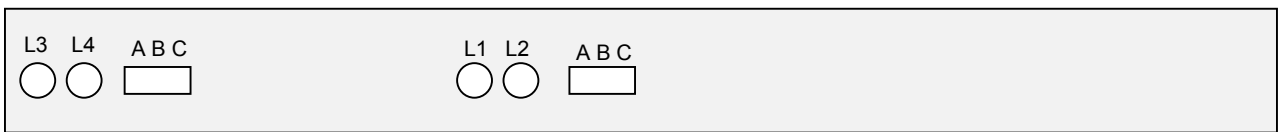

All-In-One Professional Music-On-Hold Controller /Adapter
Models: SX8800-4L, SX8800-2L Rev 29

- Plug the included AC adapter. (110/240 V AC to 12V DC)
- Confirm that all Red LED lights in front of this unit are double blinking
- Use one of your telephones and unplug the cord for L1/L2 from it and connect it to L1/L2 IN jack on SX8800, now connect L1/L2 OUT jack to your telephone using the provided phone cord, make sure you have dial tone on your lines 1 and 2
- If you have the SX8800-4L model unplug the cord for L3/L4 from your phone and connect it to L3/L4 IN jack on SX8800 (the rightmost jack) and connect L3/L4 OUT jack on SX8800 (2nd jack from right) to your telephone using the provided phone cord, make sure you have dial tone on your lines 3 and 4
- Observe that as you connect the lines the blinking lights turn OFF. (on non existing lines the lights keep blinking and that is OK)
- Alternatively you may use a splitter (T adapter) at the Wall jack to connect both this device and a telephone (in that case the L1/L2 OUT jack and L3/L4 OUT in SX8800-4L are not connected)

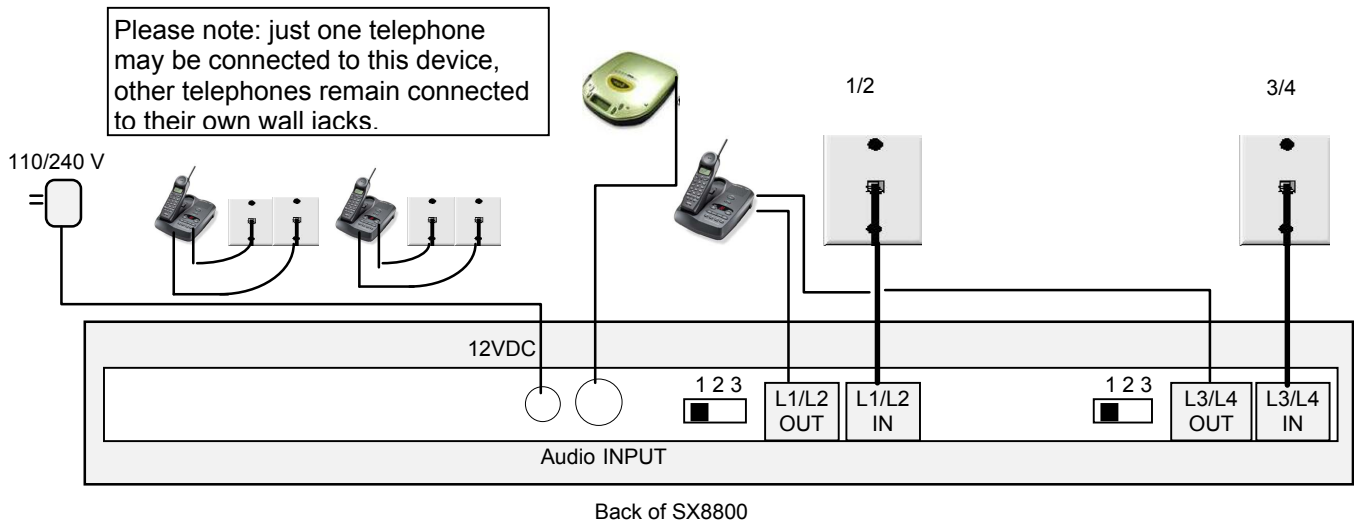

Connection Test: To confirm that you have connected everything correctly:

Connect the Audio Input to a source for audio such as a digital player, Radio, CD Player, etc. set the ABC switches in front to C position and the 123 switches in the back to 3 position, select line 1 on the phone, L1 LED on SX8800 must turn ON and you should hear audio from the phone Line 1 select line 2 on the phone, L2 LED on SX8800 must turn ON and you should hear audio from the phone Line 2 if you have the SX8800-4L:

select line 3 on the phone, L3 LED on SX8800 must turn ON and you should hear audio from the phone Line 3 select line 4 on the phone, L4 LED on SX8800 must turn ON and you should hear audio from the phone Line 4

Double check your connections or adjust the volume if needed.

This completes the test you should change the ABC and 123 switches now to proper setting as follows:

Switch setting: Please Read the Operation instructions for each setting carefully

There are pairs of 3 position switches on the SX8800 that control the activation method, you need to select the proper setting based on your type of phones:

A1, A2, A3: Hold button activation

Use one of these settings when all phones are corded & are same model (for example all are ATT 992) and are compatible with Hold button activation (see the list in page 3)

B1, B2: These two settings utilize **Flash then Hold** activation method, this setting supports any phone and any mix of brands with instant activation by pressing Flash then Hold

- Use B1 or B2 settings if your phones are Cordless type (including corded base station + portables)
- If you have mixed cordless type phones with corded type phones
- If you have corded type phones that are not all the same model for example ATT brand and Panasonic brand are both used in your office
- If you have any phone that does not activate by pressing Hold (for example ATT 1040)

B3: Hold button activation or Flash See page P4 for full details.

C1, C2: Voice Activation Mode These two settings utilize **Delayed Hold activation** method, most phones cordless or corded or mixed can be activated for music on hold in less than 15 seconds after you press HOLD.

C3: Test mode

IMPORTANT NOTE: The audio may activate in the middle of a call due to factors like excessive wiring (see page 12 item 8), bad or old wiring, existing unstable lines, sparks, too many wall jacks, Noisy phone lines, Bad telephones, "Hot Lines" (see P6 special cases)

If that ever happens, press the **FLASH** button to stop the audio! and continue your conversation. The **FLASH** button is found on every telephone, it could be labeled as **CALL WAIT / FLASH** or **LINK** or **ON** or **TALK** button

Note: Do not set the volume too loud it may flicker or shut off the on-hold audio.

Note: Do not use a Cell phone near the device to setup or test the device. Use a fax line, etc.

Operation in Hold activation:

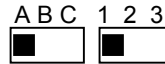

Hang up and set switches in front to A position and switches in the back to 1 position

Start with A1, make or receive a real call, the LED on the SX8800 turns ON solid, then simply press the **HOLD** button on your telephone, the Music will be heard to the caller and the LED on the SX8800 will start to BLINK , to return to the call just re-select that line. (Be sure to allow 1 or 2 seconds before putting a call on HOLD). The 1st time your are setting the device If it did not work hang up and try it again 2 or 3 times.

A2: if after 2 -3 times it is not working hang up and change the switch to A2 and try it 2-3 times.

A3: this setting works better on smaller offices with just a few phones, it is not as powerful as A1 or A2, if your phones work fine in A3 just leave it in A3.

Deactivating hold music manually If for any reason the hold music is activated inadvertently, it can be deactivated by pressing the **FLASH** button

The following are examples of phones that work in B1, B2 or C1,C2 settings: American Venture, ATT 962, ATT 972, Casio any model , Airway 2 line, Airway 4 line, Panasonic KX-TG 2000B, KX-TG4000B, KXTG2000, KX-TG2720, KX-TG2730, KX-TG2740, KXTG4000, KX-TGA200, KXTGA400, KX-TGA420, SBC 410,

List of corded phones compatible via Hold Button activation:

Please note: This is just a partial list, there are other factors relevant to activation via Hold button in these settings-see-the trouble shooting section or special setting, If your phone is not on this list try it any way or use the B1, B2 or C1, C2 settings. B1, B2 works on all phones (flash then Hold).

AT&T: 21070, 262, 272, 412, 422, 4952, 612, 622, 712, 722, 732, 742, 752, 812, 822, 830, 832, 842, 843, 853, 854, 874, 902, 912,922, 944, 945, 952, 953, 954, 955, 964, 982, 992, SIGNATURE, FT483, 974*, 984*
[* only older version prior to 2007 ,newer version works via Flash -Hold]

Brother Quatro: 412

Bell: 223, 232, 259, 261, 268, 367, 470, 52905, Sonacor 412, 412CID, 4900, BE5200, BE5300, Techline 420

GE: 187, 2-9315-A, 2-9318, 2-9435-A -B -C, 2-9436-A, 2-9438-A, 2-9450-A -B -C -D -E -F, 2-9439-A to -EGL, 2-9451A, 2-9481, 2-9487GE2-A, 2-9488, 2-9638-A, 2-9975, 2-9488GE2-A

IBM: 412, 412CID, 4900

ITL-4LT These phones are the most compatible and are available at <http://www.invotel.com>

Northern Telecom: Unity

Phonemate: PMG-4600

Panasonic: KX-T3110 3120 3122 3135 3145 3155 3160 3165 3170 3175 3280 3980-H 3980-R7 3981, KX-TC930, KX-TS20, KX-TS21, KX-TS25, KX-TS27, KX-TS208, VA-8400

Radio Shack: 206, 208, 209, 210, 212, 411, 412, 612, 43-373D, 43-430, 43-642, ET-180, 43-470, ET-184, ET-192, ET-193, 43-622, 43-469 , 1710, 1753

RCA 25403 RCA, 25413 RCA-2, all other models.

Sony: IT-M804

SBC: 2105, 4000, 225, 420

Southwestern Bell: FT325, FT360, FT365BL FT383, FT412, FT483, FT484

Sprint/Radio Shack: SP-702 / 43-5702, SP-705

TT Systems: 4012, 412, 412CID, 4900, 4300, 5100, 5200, 5300, 7993

Vtech: 4121

Operation in B1, B2 settings:

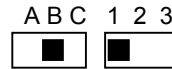

Hang up and set switches in front to B position and switches in the back to 1 position

To activate: press **FLASH** then **HOLD**

To deactivate just re-select that line and press **FLASH**

Voice Deactivation: if the call has been on Hold at least a few seconds, it can also be deactivated by just **speaking** over the Audio for example say : **“Hi I am Back”** .

If for some reason you are not able to voice -deactivate, try speaking a little louder and more direct into the microphone, if that does not work hang up and set the switches to **B2**. Remember you can always use the Flash button to deactivate the audio as well.

Want to use just one button ? Press **FLASH** to activate MOH and when ready to go back to caller just speak over the audio!. Or press Flash again. Note: this does not hold the line so the other party may still hear you, set the volume louder to mask it.

In **B1** or **B2** or **B3** settings the Flash button is used in order to activate the audio so if you have any service such as: Call waiting , 3 way calling, Centrex Call Transfer

Use **FLASH FLASH** to access an out side line or to answer a call waiting call etc.

Example 1 (B1/B2/B3 settings) to take a call waiting call press **FLASH FLASH**

Example 2 (B1/B2/B3) to make a 3 way or conference call press **FLASH FLASH** you will get a dial-tone now dial the desired phone number & press **FLASH FLASH** to join the two calls together.

Note on “Call Waiting”: If you have **“Call Waiting”** service, only one call may be placed on Music-On-Hold, the other call is held in the phone company central office in silence not in your office. What does that mean? It means it is impossible with any device to have music on hold during “call waiting” What can be done about it? contact your phone service provider, remove the call waiting and add “call rotary” or call hunting service.

Tip: If you have audio flicker problem in B2 , Reduce the Volume

B3: In this switch setting to **activate** the Hold music press **FLASH** then Hold or just press the hold button (if you have a phone which is compatible to hold button activation -see page P3). This mode is useful when you have Mix of phones that some are compatible with Hold only activation and some activate via Flash then Hold.

To **deactivate** hold music re-select that line and press the **FLASH** button. If it is a compatible phone it will automatically deactivate hold music. In B3 mode of operation the flash button is being used, so be sure to read the examples above if you have call waiting service or need to make 3 way callings etc.

Tip: If you have audio flicker problem , Reduce the Volume

Operation in C1, C2 settings:

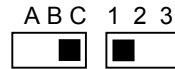

Hang up and set switches in front to C position and switches in the back to 1 position

C1 and C2 use “**voice activation**” method, this mode of operation supports most phones or brands by just using the Hold button but with slightly longer activation time (about 10 to 15 seconds after hold is pressed)

In “**Voice activation**” mode, the device needs to hear you well therefore speak as close as possible to the microphone. If you are on a speakerphone or using a headset speak clearly and louder into the microphone. Be sure to read the NOTES in this section.

To **activate**: after you receive or make a call, you need to speak and say something before pressing the **(HOLD)** button. Audio activates less than 15 seconds later and the corresponding L1 ... L4 light on this device will start blinking.

To **deactivate** hold music just re-select that line and **Speak Over** the audio, for example say : “*Hi I am Back*”, the moment the device hears it will stop the hold-music.

Note: You may also deactivate the hold-music audio by pressing the **(FLASH)** button.

NOTE1: If you hear the audio during your conversation , say something to stop the audio, this can happen if you or your party are not talking to each other for about 7 seconds. (after 2 times device will stop activating audio when non speaking for the rest of the call)

NOTE2: If for any reason the hold music is playing, do not panic, simply speak over the audio to stop it or press FLASH to stop it.

C2: If for some reason you are not able to voice activate or voice -deactivate, Hang up and set the switch to **C2** then try again using the above instructions.

Back ground Music: SX8800 can be used to provide just a back ground music during all the calls and all the lines. In this case the device will not provide the Music-on Hold function however the same back ground music is heard by the callers when the calls are placed on Hold.

To set the device for background music use an audio file in the SD card with soft music or connect a music source to EXT jack and set the Mode Switch to EXT and turn the volume low (counterclockwise) set the switches to **C3**

During the conversations the music will be heard, make sure volume is low enough to allow talking

Special Cases:

Some phones like **GE 2-9487GE2-A** , **GE 2-9488GE2-A** and all **RCA** phones beep every few seconds when the calls are placed on Hold and may not work properly in C2 or B2 settings (the beep may turn off the Hold Music in some cases) in that case use the B1 setting or use the A settings and increase the volume a bit so that the beeps are less noticeable to the callers.

If audio activates suddenly in A1 or A2 switch settings , your lines may be “too powerful” Try A3 setting.

Adapter Advanced Features:

Isolated Audio Input RCA jack
Wall mount capability via two Keyholes

Package Content:

SX8800 unit
Power adapter 110/240v AC to 12v DC 200-500 ma
2 RJ-14 phone cords
User's Manual

STATUS LED light and other LEDs:

The Status LED will turn ON **RED** solid when the device is powered ON and working. It blinks one time when the last track is played and it-re-loops.

In addition the LED lights located just below the SD card will be blinking **yellow** to indicate normal playback operation in progress or blink Red when a track or Bank change is being performed.

The L1/L2 and L3/L4 LEDs turn ON solid when corresponding line is in use, and will blink ON/OFF when Music On Hold is activated for that line and double blinks OFF when line does not exists.

(please note some music titles are not royalty-free and you may want to use the royalty-free music titles to avoid annual licensing payments to ASCAP and BMI for playing those titles on-hold)

Adapter Trouble Shooting:

Problems	Possible Cause / Solution
1. Adapter not working or stopped working	Unplug the 12VDC plug from the back of the SX8800 and unplug the phone lines; Wait 60 seconds then plug them back in, make sure the AC adapter is plugged in securely.
2. Adapter does not activate or stopped activating	telephone was changed or power failure - <u>do as above</u> , then select L1, L2, L3, L4 making sure that dial tone is there.
3. Red LED double blinks ON then turns OFF on some lines	Some phone Lines are removed from MOH adapter or do not exist. on non existing lines the lights keep blinking and that is OK) UN-plug phone lines for 5 seconds and plug it back in .
4. No Audio or Audio not Loud enough	Do the steps in “connection test” in page 2 to hear the Audio, adjust the volume if needed to hear it. Check the SD card, Remove Power Unplug SD card -Plug back IN. Reconnect Power.
5. Connection Test is OK but no audio when Hold is pressed in <u>A1</u> <u>A2</u> or <u>A3</u> settings.	<ul style="list-style-type: none"> • If answering a call allow 1 second before pressing Hold. • You may need your “Local service” to be with the dominant phone company in your area (not 3rd party local service) • Is your location within city limits? are all your phone numbers DSL qualified? your location may need to be close enough to your phone company’s central office to guarantee for Hold button activation. That is why some discount phone companies service does not work even though you have compatible phones for Hold activation. If so you need to use the device in B1 or B2 setting via Flash then Hold or C1, C2 settings with delayed activation. • Some telephones have special cases (see page 6). • Try the unit in B1,B2, B3 or C1,C2 settings.

DSL: If you have DSL line, this device needs to be installed after the DSL filter (otherwise internet may not work properly)

VOIP/Vonage: if you have D-Link VTA-VD phone adapter, you must use single line phone cords to connect it to SX8800

Problems	Possible Cause / Solution
6. MOH works but audio does not stop when call is picked up in A1 or A3 settings.	<ul style="list-style-type: none"> • Wire distance to adapter is too long, Centralize the location of device to be as close as possible to all the phones. Try the A2 setting. • If you are re-wiring “daisy chain” wiring works better than ” star” or “home run” or Independent wiring • Press FLASH button to stop the music.
7. Some Phones work , some do not	<ul style="list-style-type: none"> • All your phones need to be similar model for activation in A1...A3 settings. If you mix different phone models, Use the B1, B2, B3 settings or Voice Activation in C1, C2, settings. Refer to pages 4 or 5 for more details.
8. Randomly Hold music starts to play by it self or does not activate in A1, A2 or A3 settings	<ul style="list-style-type: none"> • The call needs to be on Hold min. 2 sec. before you may pick it up. • When you hang up, wait 2 seconds before selecting the same line again. • Check for extra devices sharing that line like Message indicator, Answering machine, Alarm system, Modem etc. Use a “privacy module” between the line and that extra device to keep them off the line when line is being used by your phone. • Set your Alarm system and/or your DSL line to share FAX line. • <u>Excessive wiring</u>- Total wire length per line must be under 500 feet (Ex: if you have 9 wall jacks -no matter spare or a phone plugged in- each connected via a 100 foot wire to a common point then your total wire length is 9 x 100=900 feet) • Use FLASH button to deactivate music.
9. Audio shuts off or flickers	<ul style="list-style-type: none"> • Extensive audio volume. Lower the volume to proper level.
10. Hold Music activates in a conference call or when two phones pick up at same time	<ul style="list-style-type: none"> • If for any reason the hold music is activated inadvertently, it can always be deactivated by pressing the FLASH button in any setting. • Conference calls can be done a better way: Press FLASH, you will get a dial-tone now dial the phone number of the 2nd party then press FLASH to join the two calls together.

Warranty

This product is warranted against defects for a period of five (5) year from the date of original invoice. We will repair/replace the product with no charge for parts or labor within this time. To obtain warranty service the product needs to be returned freight prepaid by the customer with a copy of original invoice. This warranty does not apply if in the sole opinion of Innovative Telecommunication Technology LLC, the product has been tampered with or damaged by lightning or any other acts of nature, misuse, neglect or unauthorized service.

EXCEPT AS SPECIFICALLY PROVIDED IN THIS AGREEMENT, THERE ARE NO OTHER WARRANTIES, EXPRESSED OR OTHERWISE, INCLUDING, BUT NOT LIMITED TO ANY IMPLIED WARRANTIES OR MERCHANTABILITY OR FITNESS FOR A SPECIAL PURPOSE. IN NO EVENT SHALL INNOVATIVE TELECOMMUNICATION TECHNOLOGY LLC BE LIABLE FOR LOSS OF PROFITS OR BENEFITS, INDIRECT, SPECIAL, CONSEQUENTIAL OR OTHERWISE ARISING FROM ANY BREACH OF THIS WARRANTY OR OTHERWISE.